

LIFT-RITE

MODEL:

ERGO 3000
nomic



*Matching of People
and Machinery
Requirements*

3000 lbs. Capacity



Electric or Manual Lift

LIFT-RITE®

ERGO 3000 nomic Technical Specifications

Capacity	3,000 lbs.
Load Centre	24"
Lowered Height	3-1/4"
Raised Height	31-1/2"
*Fork Length	48"
Fork Width	7"
*Overall Width	20-1/2" & 27"
Overall Length	64-1/2"
Weight(Manual)	340 lbs.
Weight(Electric)	440 lbs.
†Load Wheels	8" Dia. Polyurethane
†Load Rollers	3" Dia. Polyurethane
Steering Arc	180 degrees
Scissor Construction	Solid Steel bar

Electric model includes 12 volt battery and built-in charger (110/1/60)

*Various widths and lengths available on request.
 †Steel and Nylon also available as standard.
 Electric upgrade (on manual units) available from your Lift-Rite Stocking Dealers.

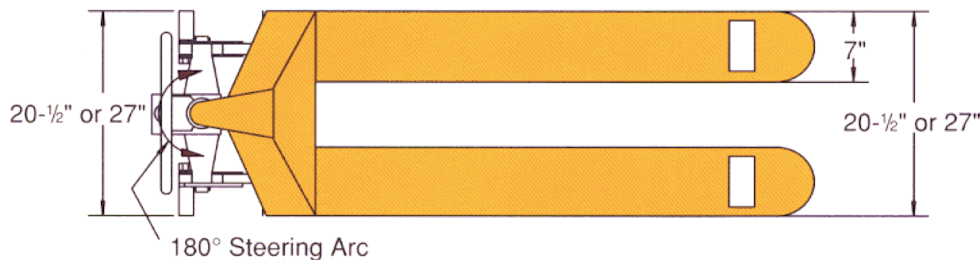
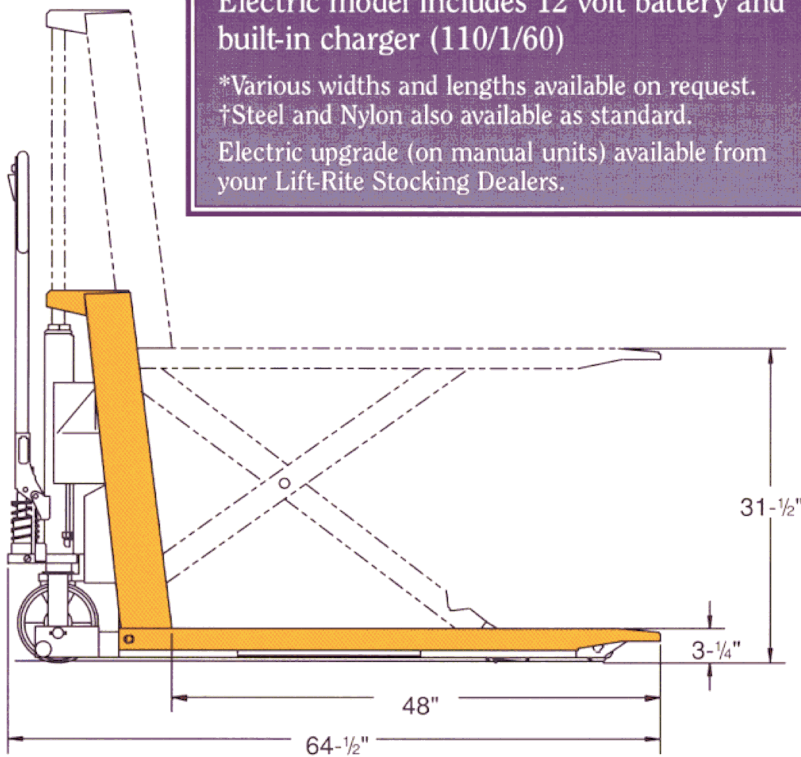

Manual Ergonomic 3000

The portable lift table features manual Quik-Lift with ease positioning for a wide variety of applications.



Electric Ergonomic 3000

A manual operated, electric-powered scissor lift table designed for applications where raising and lowering are more frequent.

Ergonomic 3000: *Matching of People and Machinery Requirements*

Ergonomic improvements boost productivity, cut costs, and create a safer workplace.