



L45 SS Stainless Steel Hand Pallet Truck

Specially designed for corrosive environments or applications that demand high standards of hygiene, such as food processing, pharmaceutical, and marine industries.

All components are manufactured from Stainless Steel or other non-corroding materials, which gives the truck reliability and long life.

All surfaces are glass blasted to provide a smooth surface and allow easy cleaning.

10 grease fittings allow for grease replenishment to protect against corrosion.

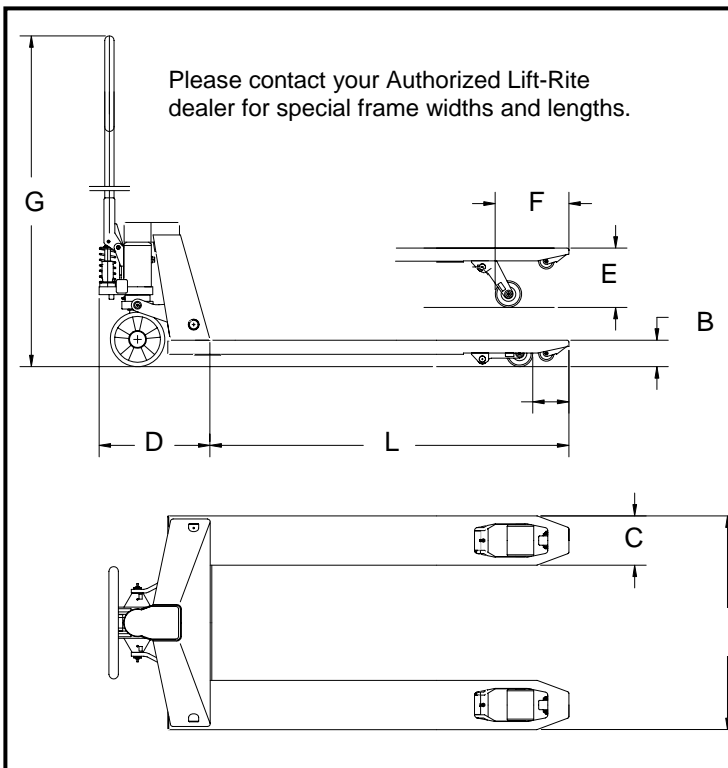

Specifications

Rated Capacity	4500 lbs.
Weight	155 lbs.
Steer Wheels	7" Diameter
Load Rollers	2.95" Dia.

(Dimensions)

A – Frame Width	27 inches
B – Lowered Height	2.9 inches
C – Fork Width	6.25 inches
D – Truck Length	14 inches
E – Raised Height	7.5 inches
F – Roller Travel	10.5 inches
G – Handle Height	48 inches
L – Fork Length	48 inches